

TECHNICAL DATA SHEET - Universal Adapter Bracket for 32" - 60" Flat Panel Screens



MODELS: PLP-UNL, PLP-UNLP, PLP-UNL-S, PLP-UNLP-S

The Universal Adapter Bracket offers unparalleled compatibility with medium to large sized plasma and LCD flat panel screens 32" - 60". The heavy duty reinforced plate and brackets hold up to 200 lb and quickly and easily attach to most Peerless flat panel mounts. Includes pre-sorted fastener kit with all necessary screen hardware and both shallow and deep brackets to attach to screens with a component box or tuner on the back.

Features:

- Universal plate fits virtually any 32" to 60" screen
- Compatible with most Peerless flat panel mounts: PLA-1, PLA-2, PLB, PLCM-1, PLCM-1CP, PLT, PLCT, COL, MDJ (**mounts sold separately**)
- Security models available provide effective theft deterrence
- Reinforced plate and brackets hold up to 200 lb
- Scratch resistant fused epoxy finish
- Pre-sorted fastener pack for quick and easy assembly
- Heavy gauge cold rolled steel construction
- Available in black or silver

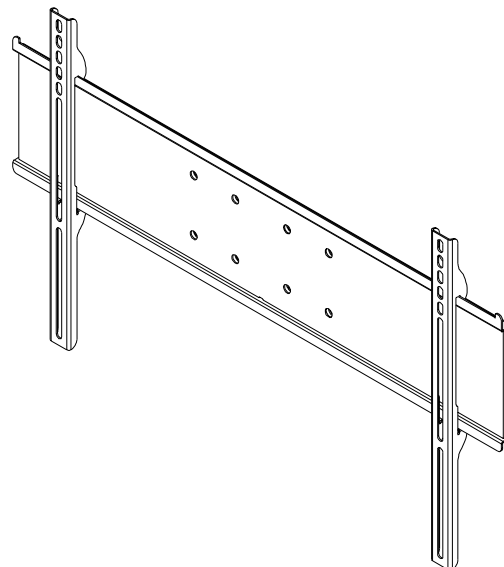

Dimensions:

Weight:

11.4 lb (5.2 kg)

Shipping weight:

14.6 lb (6.6 kg)

Maximum Load Capacity:

200 lb (90.7 kg)

Shipping Carton dimensions:

L= 32.5 in (826 mm)

W= 8.75 in (222 mm)

H= 4.75 in (121 mm)

ARCHITECTS SPECIFICATIONS

The Universal Adapter Bracket shall be a Peerless model _____ and shall be located where indicated on the plans. It shall be constructed of heavy gauge steel. The finish shall be scratch resistant black or silver fused epoxy. Assembly and installation shall be done according to instructions provided by the manufacturer.

Peerless Industries, Inc.

3215 W. North Ave. Melrose Park, IL 60160
708-865-8870 800-865-2112 Fax 708-865-2941

www.peerlessmounts.com

ISSUED: 11-22-05 SHEET NO: 202-9506-1

©2005 Peerless Industries, Inc. All rights reserved.
Peerless is a registered trademark of Peerless Industries, Inc.
All other brand and product names are trademarks or registered trademarks of their respective owners.

TECHNICAL DATA SHEET

MODELS: PLP-UNL, PLP-UNLP, PLP-UNL-S, PLP-UNLP-S

ALL DIMENSION = INCH
(MM)

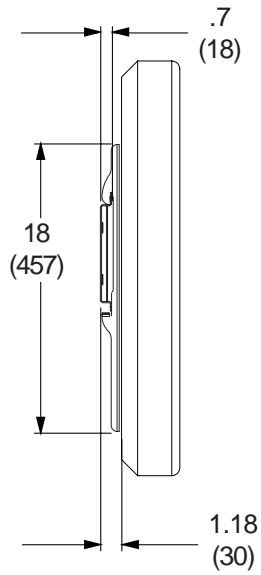

**SIDE VIEW
WITH SHALLOW
BRACKET**

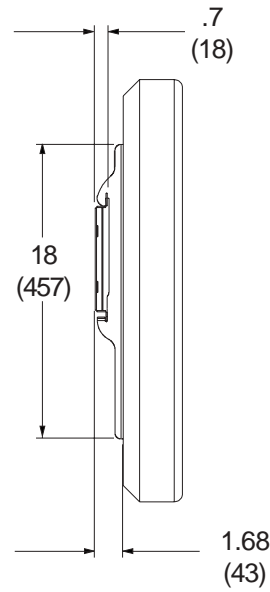

**SIDE VIEW
WITH DEEP
BRACKET**

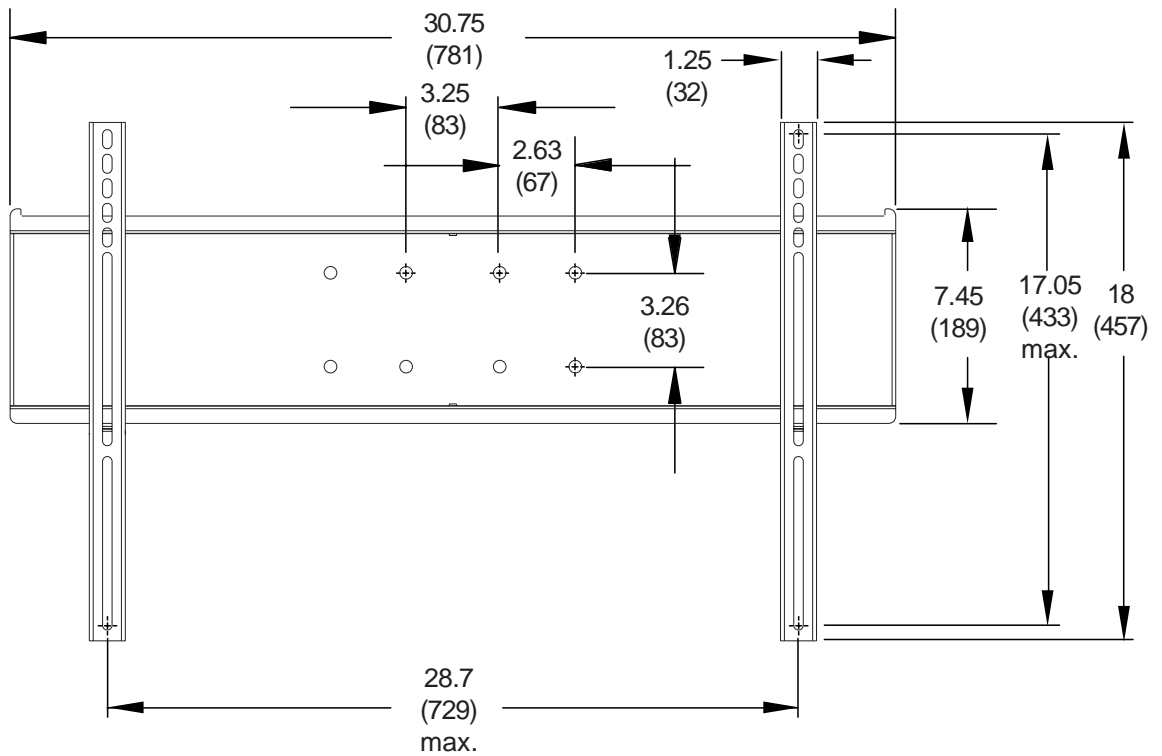

ADAPTER BRACKET DETAIL